

Title 15 - Mississippi State Department of Health

Part III – Office of Health Protection

Subpart 77 – Onsite Wastewater

APPENDIX 02 DESIGN STANDARD: AGGREGATE

100 INTRODUCTION

In a conventional onsite wastewater system treatment begins in the septic tank, under anaerobic conditions. Final treatment and disposal takes place in the soil of the drainfield, an aerobic environment. It is necessary for this aerobic condition to exist in the soil of the drainfield for proper treatment of the effluent.

101 DEFINITIONS

101.01 Aggregate System – any subsurface disposal system that utilizes gravel, crushed stone, tire chips or other approved aggregate media.

101.02 Conventional Subsurface Aggregate Disposal System – any gravity-fed subsurface disposal field utilizing a loose aggregate media ranging from 36 to 12 inches in depth.

Standard Subsurface Disposal 25 in. to 36 in.
Shallow Subsurface Disposal 12 in. to 24 in.

101.03 Tire Chips – Coarse aggregate made from recycled tires to substitute volumetrically for mineral aggregate for use as media in a conventional subsurface disposal field.

102 SITE EVALUATION

102.01 Information obtained during the soil and site evaluation will determine which type(s) of IOWDS may be utilized for an individual lot.

102.02 Prior to completing the Soil and Site Evaluation/System Recommendation, the Environmentalist shall visit the lot and conduct the soil and site evaluation.

102.03 The soil determinations will be made based on soil borings to a depth of five feet or to a depth sufficient to reach a restrictive horizon. Restrictive soil or site conditions may preclude the use of any subsurface disposal system.

102.04 A soil and site evaluation will be based on the following criteria:

1. Absence of or protection from frequent flooding.
2. Landscape position with good surface runoff.
3. Slopes of less than 15%.
4. Depth to high water table of greater than four feet.
5. Depth to bedrock, fragipan or plinthite of greater than four feet.
6. Soil texture and color defined by the Natural Resource Conservation Service as indicating good drainage and suitability for soil absorption, based on a soil boring of five feet.
7. Available area in which to install an individual onsite wastewater disposal system meeting all requirements of this regulation. The area for repairs and future extensions shall be no less than 50% of the space required for the recommended system. Systems utilizing surface land application discharge are exempt from the 50% additional area requirement.
8. The non compliance of one or more of the above items may require a design alteration of an underground system.

103 LOCATION OF ONSITE WASTEWATER DISPOSAL SYSTEMS

103.01 All components of the onsite wastewater disposal system shall be located a minimum of:

1. five feet from any dwelling.
2. ten feet from any property line.

103.02 Any vessel holding wastewater shall be located a minimum of 50 feet from any public, private or individual potable water source.

103.03 The effluent disposal field shall be located at a lower elevation or in a landscape position that will preclude any surface runoff from flowing in the direction of the well site and a minimum of 100 feet from any public, private or individual potable water source.

103.04 Potable water lines shall not pass under or through any part of the sewage disposal system. Where a water supply line must cross a sewer line, the bottom of the water service within ten feet of the point of crossing, shall be at least 12 inches above the top of the sewer line. The sewer line shall be of Schedule 40 pipe with cemented joints at least ten feet on either side of the crossing. Water and sewer lines shall not be laid in the same trench. The water and sewer lines, when laid on the same elevation, shall maintain a minimum separation distance of 10 feet.

103.05 The surface of or the surface above the disposal field shall not be used for vehicular traffic or vehicular parking.

- 103.06 No portion of an onsite wastewater disposal system shall be located under dwellings or other permanent structures.
- 103.07 Effluent disposal systems shall not be located in depressed areas where surface water will accumulate. Provision shall be made to minimize the flow of surface water over the effluent disposal field.
- 103.08 Subsurface wastewater disposal field setbacks from sensitive waters. [See Table I].
- 103.10 Slopes of greater than 30% shall not be considered for subsurface disposal installation.
- 103.11 Where all or part of the onsite wastewater disposal system is proposed to be installed on property other than the owner's, an easement in perpetuity shall be legally recorded in the proper county. The easement shall be of sufficient area to permit access, construction and maintenance of the onsite sewage disposal system.
- 103.12 No site for an effluent disposal field or expansion area shall be approved which is located wholly within an area which is frequently flooded, swamp, marsh, or wetland. Except that if permits have been issued by the proper regulatory agency authorizing the use of wetlands for building sites, the property shall be evaluated using standard soil and site criteria for IOWDS.
- 103.13 When a proposed lot is located partially within a frequently flooded area, that portion of said lot not within the flood prone area may be considered for approval for the effluent disposal field.
- 103.14 There shall be maintained a minimum of 12 inches of unsaturated soil between the bottom of the subsurface disposal system and a perched or seasonal water table in soils that contain a restrictive horizon (fragipan, chalk, bedrock, clay or silty clay) within five feet of the surface.
- 103.15 There shall be maintained a minimum of 24 inches of unsaturated soil between the bottom of the subsurface disposal system and any perched or seasonal water table in soils that do not contain a restrictive horizon (fragipan, chalk, bedrock, clay or silty clay) within five feet of the surface.
- 103.16 Easements or right-of-way areas for utilities, surface or subsurface drainage, roads, streets, ponds or lakes shall not be used as available space for location of individual onsite sewage disposal systems.

104 UNDERGROUND ABSORPTION

- 104.01 The size of the subsurface sewage disposal system shall be determined by soil texture [See Table II].
- 104.02 Soils with excessively rapid permeability rates, gravel and coarse sand, shall be considered unsuitable for subsurface disposal unless the native soil is replaced with a suitably thick (greater than two feet) layer of loamy sand or sand textured soil.
- 104.03 Soils with excessively slow permeability rates, silty clay and clay, shall be considered unsuitable for conventional subsurface disposal.
- 104.04 Subsurface disposal systems shall be placed no deeper than 36 inches below the surface.
- 104.05 Conventional subsurface disposal systems shall have a minimum 12 inches of soil backfill [Figure 1][Figure 2].
- 104.06 The minimum distance between absorption trench sidewalls shall be six feet.
- 104.07 Aggregate-type absorption trenches shall be a minimum of 24 inches and a maximum of 36 inches in width.
- 104.08 Trenches shall not be excavated when the soil is wet enough to smear or compact easily.
- 104.09 The bottom of the trenches or bed and the distribution lines shall have a grade from level to no greater than two inches fall per 100 feet.
- 104.10 There shall be a minimum of three feet of undisturbed soil between the excavation for the septic tank or treatment plant and the beginning of the absorption trench, bed or effluent line.
- 104.11 Media for the disposal fields shall extend from at least two inches above the top of the perforated field line pipe to at least six inches below the bottom of the perforated field line pipe a minimum of 12 inches total [Figure 1].
- 104.12 Stone media for the disposal fields shall consist of crushed rock, gravel or other suitable material, as approved by the Mississippi Department of Health, Division of Onsite Wastewater, varying in size from $\frac{1}{2}$ to $2\frac{1}{2}$ inches. The material shall be free from dust, sand, clay, or excessive fines.
- 104.13 Tire chips shall be allowed for use as coarse aggregate in onsite wastewater treatment and disposal system drainfields and may substitute for stone aggregate

on a one-for-one basis, volumetrically when the following physical properties are met:

1. Tire chips are to be a normal two (2) inches in size and may range from one-half (1/2) inch to a maximum of four (4) inches in any direction.
2. Exposed wire may protrude no more than one-half (1/2) inch from the sides of the chip. No more than (10%) by weight shall exceed this standard.
3. No more than (10%) by weight shall pass through a one-half (1/2) inch screen.
4. At least 80% of the bead wire must be removed from the tires to be chipped.
5. Fines of less than 2 mm in size are prohibited. Fines in this context is defined as particles or substances which can settle to the bottom of the absorption trench and contribute to the clogging or blocking of infiltrative surfaces (dirt, dust, grit, crumb rubber and similar substances).

104.14 The media for the disposal fields shall be covered with untreated building paper, heavy craft paper, a layer of straw at least two inches thick, or other acceptable material, as approved by the Mississippi Department of Health, Division of Onsite Wastewater.

104.15 Soil material excavated from trenches shall be used in backfilling and should be left mounded over the trenches until initial settling has taken place.

104.16 When a change in elevation of the disposal trench is required, a connecting lateral or crossover must be used. At the point where a crossover line leaves a lateral, the trench for the crossover line shall be dug no deeper than the top of the aggregate in the preceding trench so that an undisturbed block of earth will remain in place for the full depth of the aggregate. Crossover lines shall be laid on undisturbed earth. The invert of the crossover must be at least four inches lower than the invert of the septic tank effluent line.

104.17 Standard manufactured fittings compatible with the pipe shall be used to connect all pipes within the effluent disposal field.

105 CERTIFICATION

105.01 Any manufacturer wishing to provide tire chips for use in onsite sewage treatment and disposal system drainfields in the state of Mississippi must first

receive a certification from the State Department of Health, Division of Onsite Wastewater. Manufacturers must provide proof they can produce a tire chip coarse aggregate in conformance with the standards in Section V, part 13.

105.02 Tire chip coarse aggregate from certified manufacturers shall be labeled as drainfield aggregate on the freight bill-of-lading. The bill-of-lading shall clearly certify that the material meets the requirements for drainfield use. Contractors purchasing tire chip coarse aggregate shall retain a copy of the freight bill-of-lading as documentation of the aggregate size and quality.

106 **ALTERNATING DISPOSAL FIELDS**

106.01 An alternating effluent disposal field system provides two complete disposal fields, separated by a valving system so that each system could alternately be used and rested. This "resting" has shown to be useful in regenerating the soil's capability for absorbing the effluent.

106.02 The size of each field can be from 50 to 100 percent of the required square footage of a single disposal field.

106.03 The length of time each field would be used and then rested will be determined on a case-by-case basis.

107 **SHALLOW DISPOSAL FIELDS**

Shallow aggregate systems can sometimes be used where the depth to the restrictive horizon or water table is less than 25 inches. Placement of the system may be as shallow as 12 inches for aggregate systems [Figure 2 and Section IV part 14 and 15 of this design standard]. Shallow installations may be placed in any texture shown as suitable in Table II.

108 **ABSORPTION BEDS**

108.01 Absorption beds and trenches should be located a minimum of 10 feet from any trees, except for subsurface drip irrigation.

108.02 Absorption beds have a smaller "footprint" than the same square footage of trench system. This lends them useful in certain installations where the amount of useable space is limited.[FIGURE 3].

108.03 The amount of bottom absorption area required shall be the same as shown in [TABLE II]. The bottom of the bed should have a relatively level grade.

108.04 Lines for distributing effluent shall be spaced from 3 to 6 feet apart and not greater than 3 feet from the sidewall. The number of lines will depend on the square feet and width of the bed to be constructed.

- 108.05 Care should be taken to prevent heavy machinery from damaging the bed during backfilling.
- 108.06 The effluent must be equally distributed to the bed by means of a distribution box or with a pipe manifold [FIGURE 4].

109 **DISTRIBUTION OF EFFLUENT**

- 109.01 When a change in elevation of the disposal trench is required, a distribution box, connecting lateral or crossover must be used. At the point where a crossover line leaves a lateral, the trench for the crossover line shall be dug no deeper than the top of the aggregate in the preceding trench so that an undisturbed block of earth will remain in place for the full depth of the aggregate. The distribution box shall be level and supply all lines equally. Field lines must be equal lengths when served by one distribution box.
- 109.02 Distribution boxes may be used to connect the effluent line to the effluent distribution lines. Non-perforated rigid pipe shall exit the distribution box for a minimum of five feet at level grade before the effluent distribution line (perforations) begins [FIGURE 7].
- 109.03 Crossover lines shall be laid on undisturbed earth. The invert of the crossover must be at least four inches lower than the invert of the septic tank outlet line.

Crossovers shall be constructed as shown in FIGURE 5.

Table I

SETBACK REQUIREMENTS FROM SENSITIVE WATER

Minimum Distance from the Water Edge

Soil Textural Class	Slope of Less Than 8 Percent	Slope of More Than 8 Percent
Gravel	NOT APPLICABLE	
Coarse Sand	50 feet	50 feet
Medium Sand	50 feet	50 feet
Fine Sand	50 feet	50 feet
Loamy Sand	50 feet	50 feet
Sandy Loam	50 feet	50 feet
Light Loam	50 feet	50 feet
Heavy Loam	50 feet	50 feet
Silt Loam	50 feet	50 feet
Sandy Clay Loam	50 feet	50 feet
Light Clay Loam	50 feet	50 feet
Heavy Clay Loam	50 feet	50 feet
Light Silty Clay Loam	50 feet	50 feet
Heavy Silty Clay Loam	50 feet	50 feet
Sandy Clay	50 feet	50 feet
Silty Clay	50 feet	50 feet
Clay	50 feet	50 feet

The effluent disposal setback is based on the soil texture of the horizon in which the absorption trench or bed is to be placed.

These setbacks are to be used on all Individual On-site Wastewater Disposal Systems except **Spray Irrigation and Overland Discharge**.

TABLE II RESULTS OF SOIL EVALUATION

The following rates should be used to size conventional subsurface disposal systems: (See also Section 2.8)

Soil Textural Class	Ribbon Length (inches)	EPA Manual Appl. rate gpd/ft ²	^A Absorption Area in sq. ft./bedroom	Additional absorption area in ft. ² /person over 2 persons/bedroom
Gravel and Coarse Sand	Not Suitable ^B			
Coarse to Medium Sand	-	1.2	125	60
Fine Sand, Loamy Sand	-	0.8	190	95
Sandy Loam	<.5	0.6	250	125
Loam	<.5	0.6	250	125
	.5-1	0.45	335	165
Silt Loam	<1	0.45	335	165
Sandy Clay Loam	1-2	0.45	335	165
*Silty Clay Loam or, *Clay Loam	1-1.5	0.30	500	250
	1.5-2.0	0.20	750	375
Sandy Clay, Silty Clay, Clay	>2.0	Not Suitable		

A. Length of field line = $\frac{\text{Total sq. ft. of Absorption Area}}{\text{Width of Trench (ft.)}}$

B. See Section 2.15

*Construction should proceed when the soil is sufficiently dry to resist compaction and smearing during excavation. This point is reached when soil material crumbles when trying to roll a sample into a wire between the palms of the hands.

Figure 1
Conventional Subsurface Absorption

Trench Cross Section

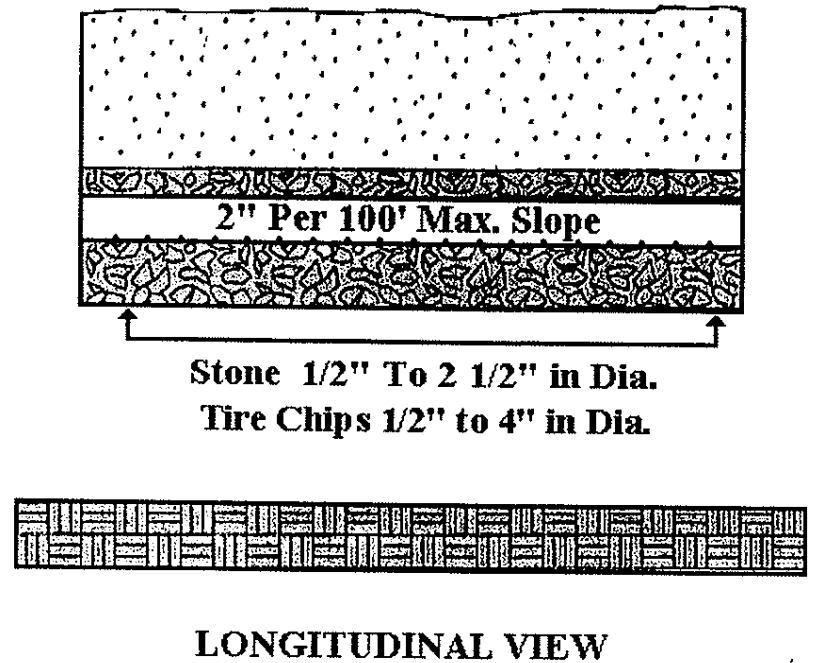
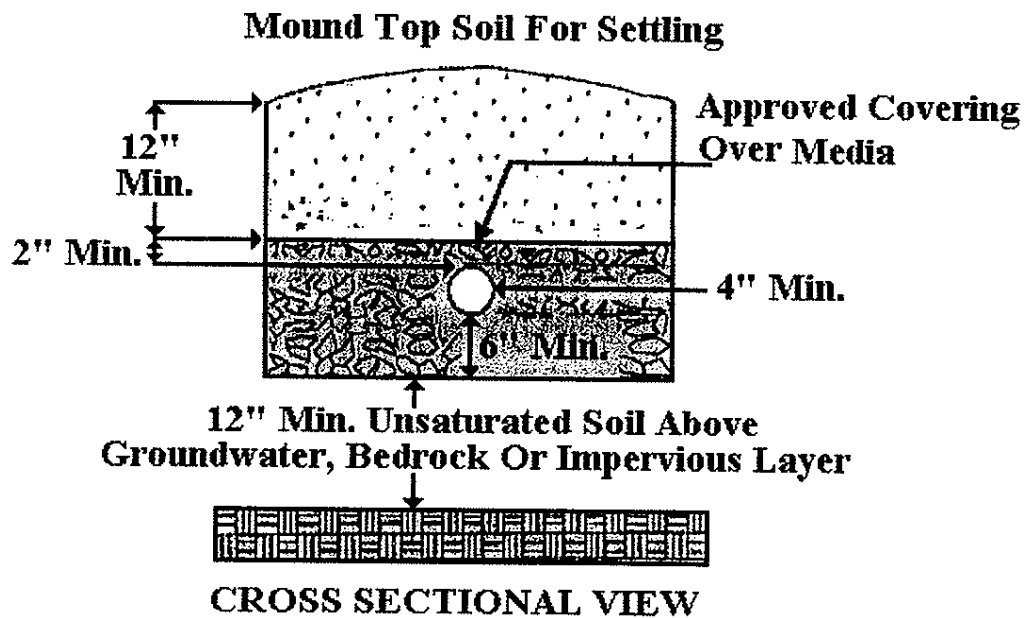

Figure 2
Ultra Shallow Absorption Field

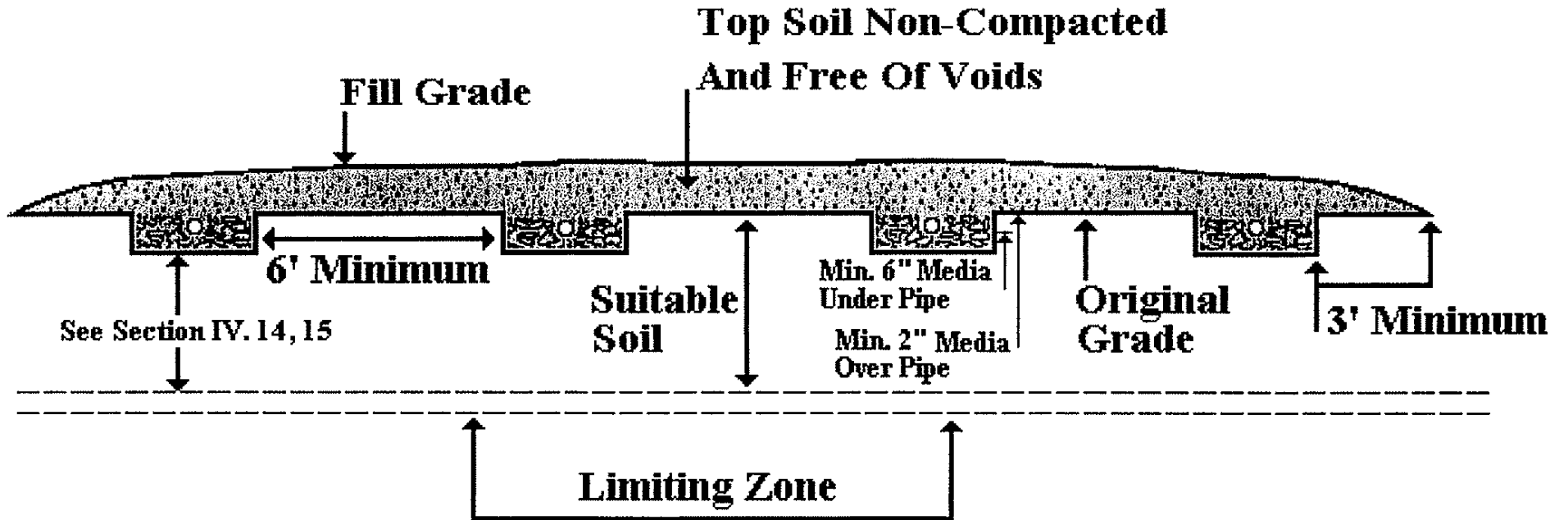

Figure 3
Conventional Absorption Bed

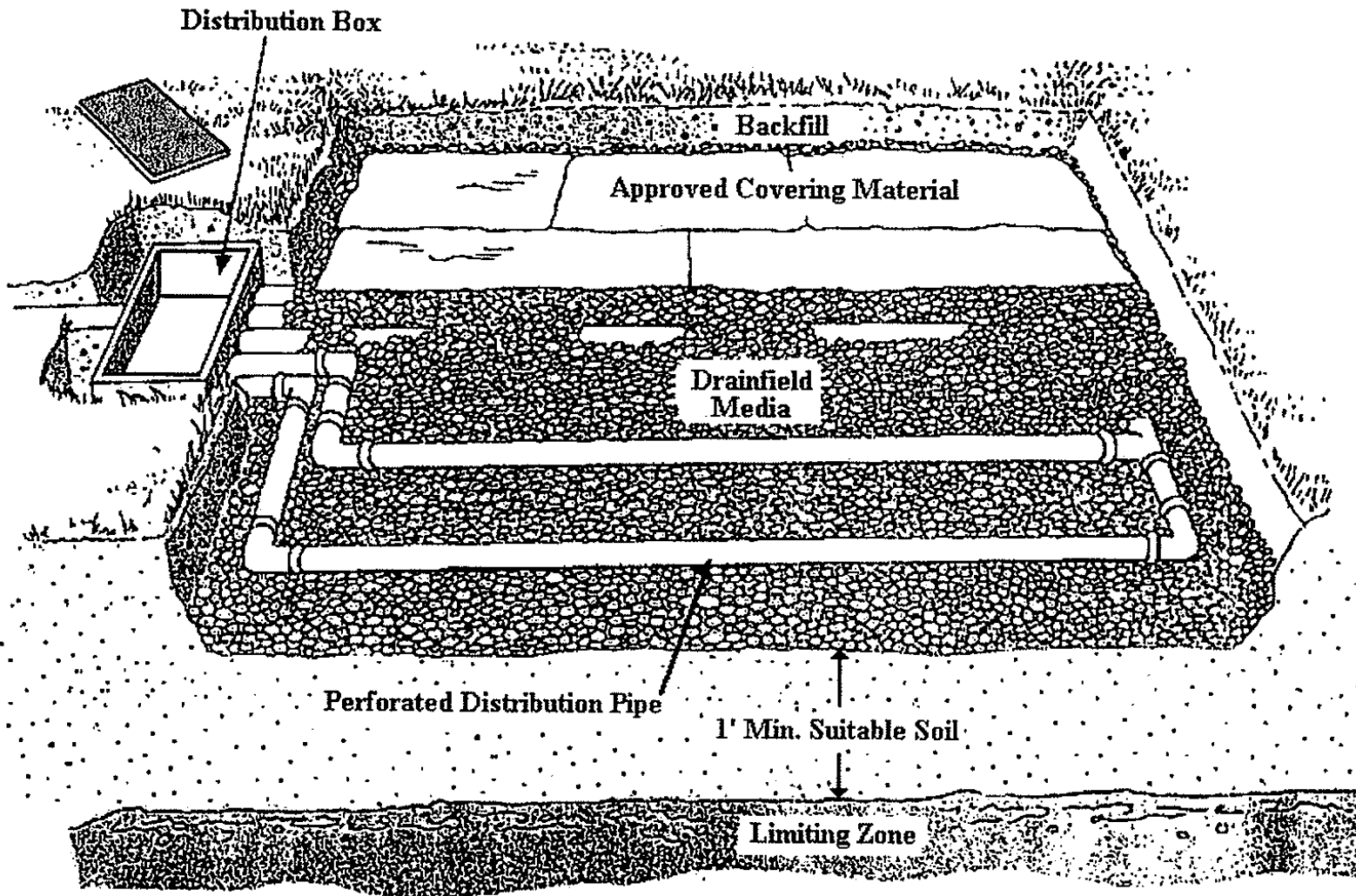
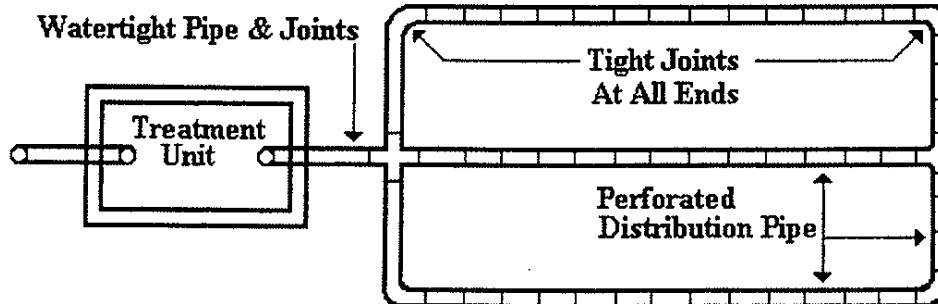

Figure 4
Effluent Distribution
for
Absorption Beds

Pipe Manifold Type
Drawing I



In absorption bed systems where the entire infiltrative surface is at one elevation closed loop networks may be used. The distribution pipe is laid level over the media filled excavation and the ends connected together with additional pipe with ell or tee fittings.

Distribution Box Type
Drawing II

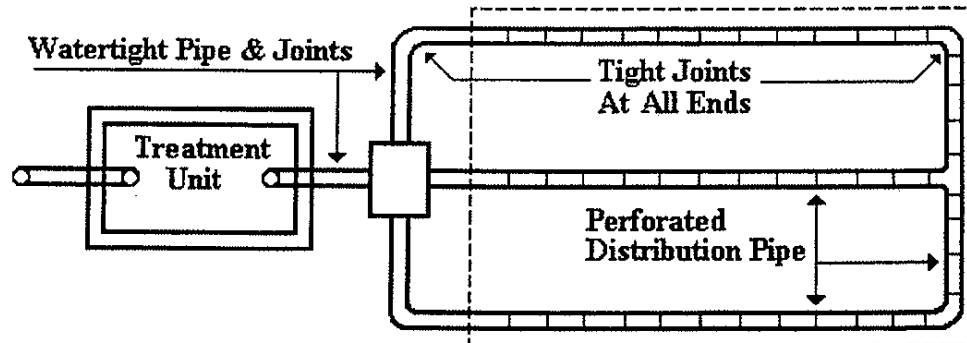

Distribution box networks may be used in beds with independent distribution laterals. The distribution laterals in the network extend from a common watertight box called the distribution box. The box may be round or rectangular, with a single inlet, and an outlet for each distribution lateral.

Figure 5
Connecting Lateral
[Spill Overs]

Connecting laterals must be used when changes in elevation of subsurface disposal fields is necessary. Connecting laterals must be constructed according to Drawing I.

DRAWING I

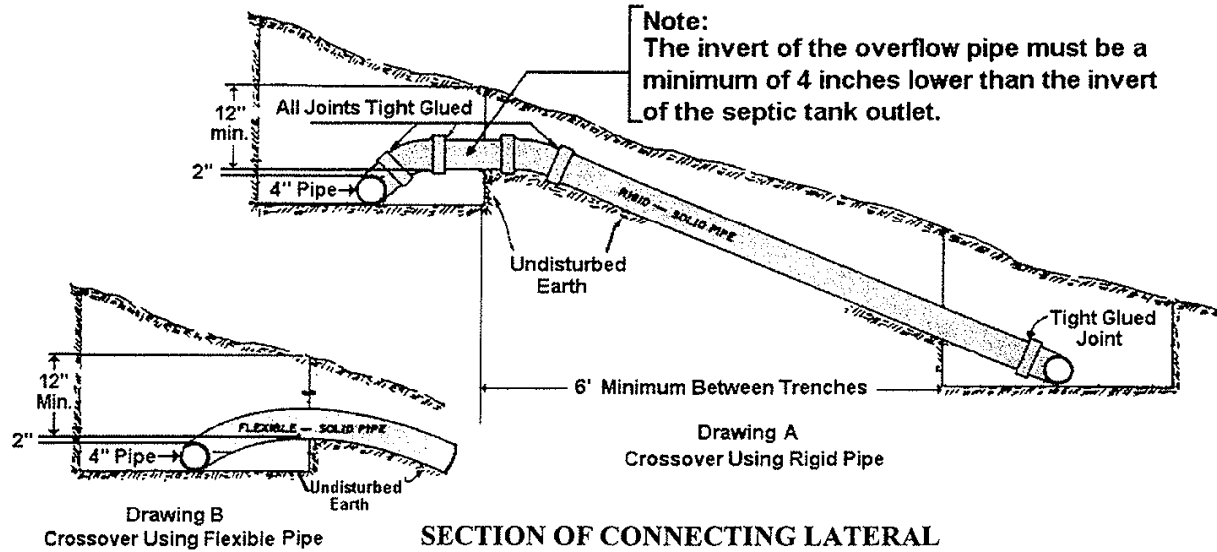

CONNECTING LATERAL ON SLOPING GROUND

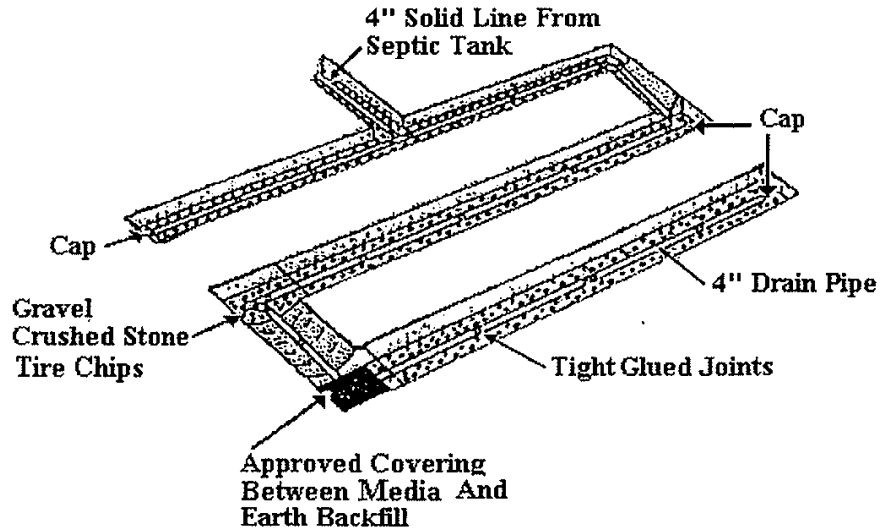
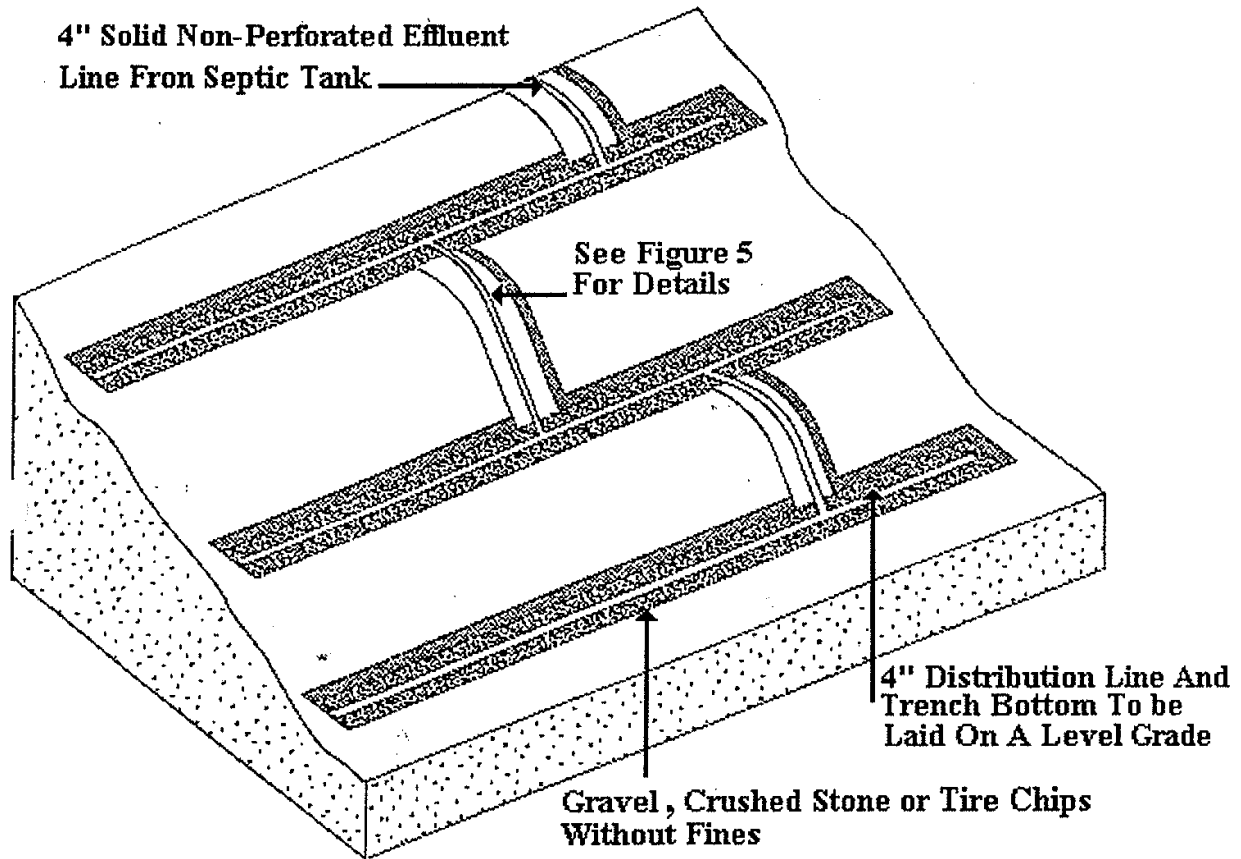
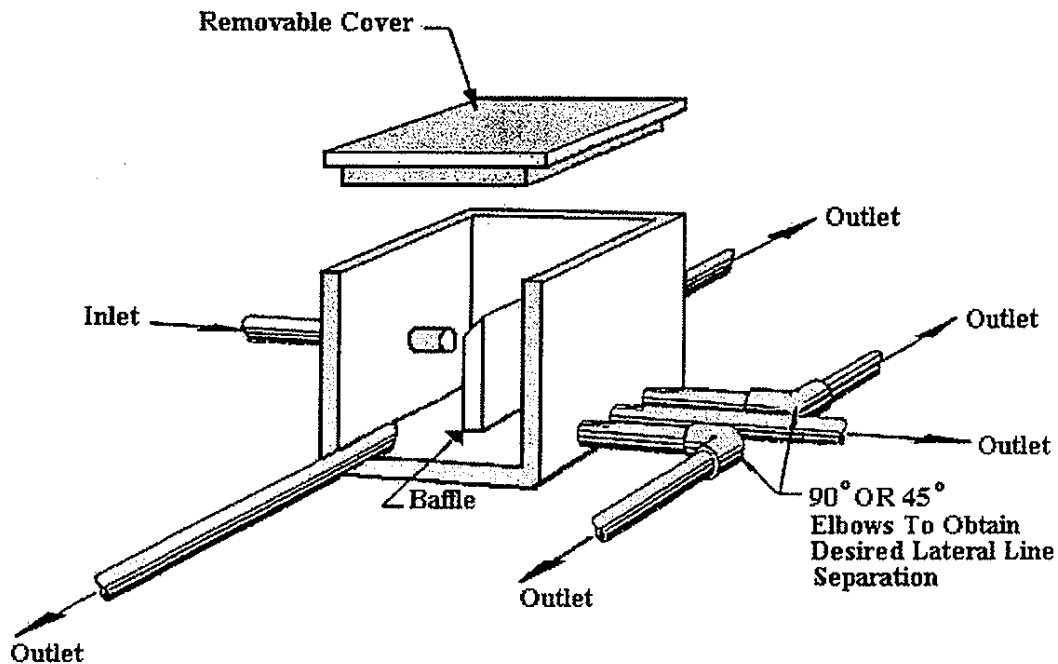

Figure 6
Connecting Laterals
Alternative Placement of Laterals on Sloping Ground



**Figure 7
Distribution Box**



The following shall also apply:

1. Each lateral line shall be connected separately and not subdivided.
2. Inverts shall be at the same elevation.
3. Outlet lines should have equal slopes for five feet after leaving the "D" box.
4. A baffle is to be used when effluent is delivered by a pump or siphon, or the slope of the inlet line is such that uneven distribution could occur.
5. The top of the baffle must be level with the crown of the inlet pipe.
6. The bottom of the inlet pipe should be a minimum 1 inch higher than the bottom of the outlet pipe(s).